

LEDIM/D2

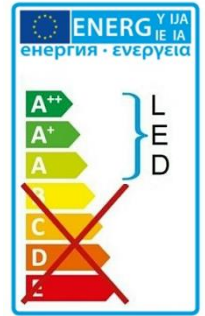

Flicker-Free Analog Single Channel Intelligent LED Dimming Driver
Touch/Pushbutton/Potentiometer/PWM/LDX Dimming Control
Part-No.: LD2-G1-D<d>-C<cccc>

Designed and produced in Germany

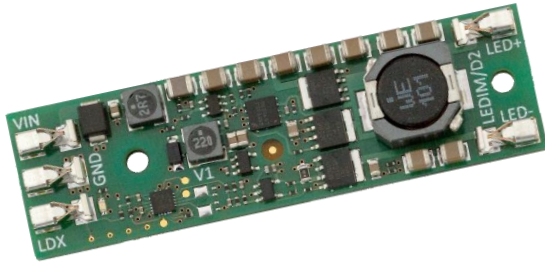

Features

- Single channel high efficiency driver with constant current output up to 50 W, 1.5 A
- Analog dimming – 100% flicker-free
- Dimming down to 0% (Dim-To-Dark)
- Simple DC power-supply up to 48 V depending on application.
- 20 mm width – ready to fit super compact applications
- Dimming controls: LDX, PWM, Touch, Pushbutton, Potentiometer

LEDIM/Solutions

- Open frame solution for 2-wire Dim-To-Warm (single channel)
- Dim-To-Warm with mating LEDIM/Cx LED engines: Dimmed light gets warmer with decreasing brightness - from cold white to candle light

Applications

- Household appliances
- Decorative lighting
- Restaurant, Bar & Hotel
- Task lighting
- Architectural lighting

Variants

- LDX Dimming
- PWM Dimming
- Potentiometer Dimming
- Touch/Pushbutton Dimming

1. Technical Data

Parameter	Value	Tolerance	Unit
Dimensions	L = 70 x W = 20 x h = 8	-	mm
Operating Temp.	-20 ... +70 (see 8.2 for details)	-	°C
Storage Temp.	-40 ... +80	-	°C
Humidity	non condensing	-	-
Supply Voltage (V ₊)	13 ... 48	-	V DC
Max. Output Voltage	0.95 x V ₊	-	V DC
Max. Output Current	1.5	-	A
Max. Output Power	50	-	W
Standby Power	0.15	+/- 0.05	W
LDX/PWM Input Voltage	0 ... 10 (recommended: max. 5)	-	V
PWM Input Frequency	200 ... 5000	-	Hz

2. Ordering Information

Part Number	Product	Dimming
LD2-G1-DL-C<cccc>	D2, Open-Frame	LDX ¹
LD2-G1-DP-C<cccc>	D2, Open-Frame	Potentiometer or PWM
LD2-G1-DT-C<cccc>	D2, Open-Frame	Touch/Pushbutton

With cccc = max. output current ("nominal current") in mA. Available nominal currents are: 0350/0500/0700/1000/1500 mA².

¹ LDX is used within ModularSystem as the interconnect signal between Bx and Dx devices, see chapter 4.

² Other current values are available on request or can be tailored.

3. Outline Dimensions

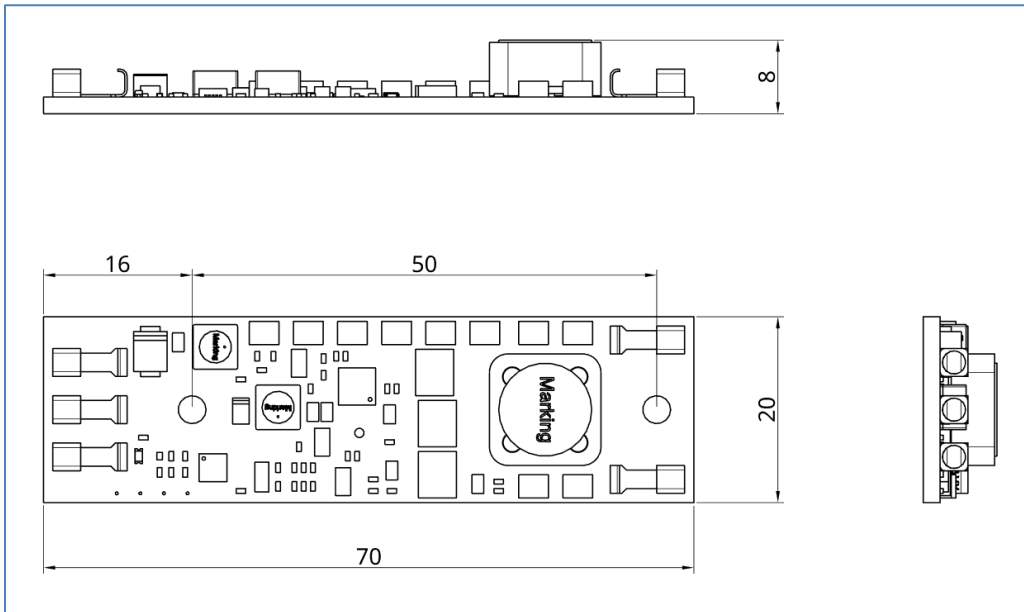

Figure 1: Outline Dimensions D2 Open-Frame (PCB)

4. LDX Dimming

LDX Dimming is used in conjunction with Bridge Devices which are part of the LEDIM ModularSystem³.

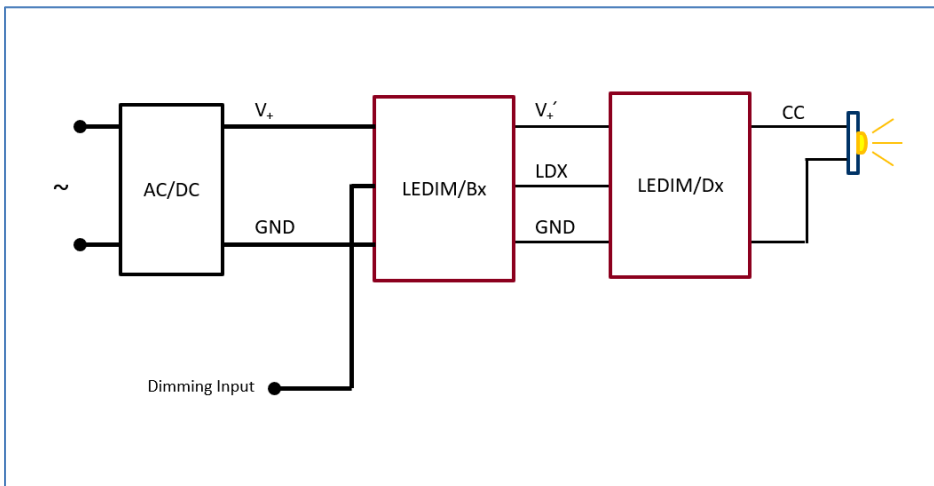

Figure 2: LDX Dimming illustrated

³ For further information about the ModularSystem, please refer to your sales representative or www.ledim.de

5. PWM Dimming

LEDIM/D2 can be dimmed with every other PWM source complying with the input requirements according to chapter 1.

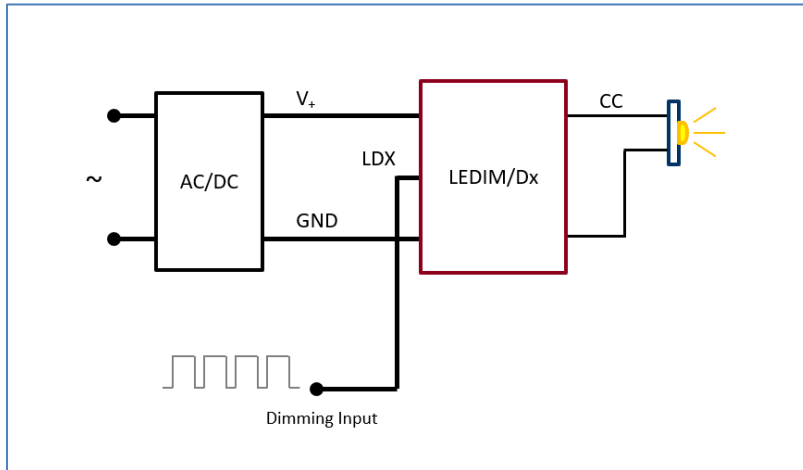

Figure 3: PWM Dimming illustrated

PLEASE NOTE: Although PWM dimming is used as the input signal, the resulting output constant current remains 100% flicker-free.

6. Potentiometer Dimming

LEDIM/D2 can alternatively be dimmed by connecting a variable resistor (50 k Ω) to the control input:

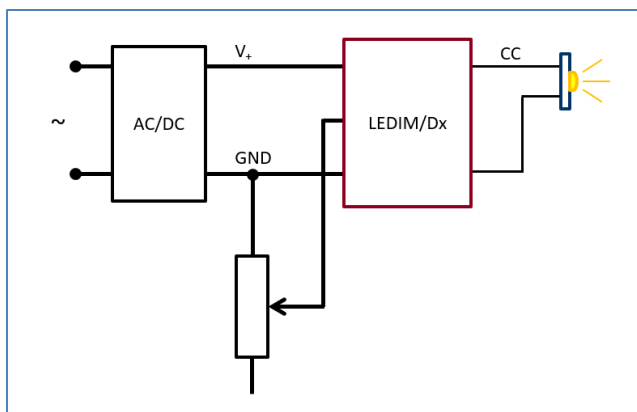

Figure 4: Potentiometer Dimming illustrated

7. Touch/Pushbutton Dimming

7.1 Touch/Pushbutton Dimming Operation

LEDIM/D2 can also be dimmed by 'relative dimming' using a pushbutton connected to its control input or in touch dimming configuration. As both pushbutton and touch are using the same principle of dimming relative to the current state, they are bespoken equal in the following section.

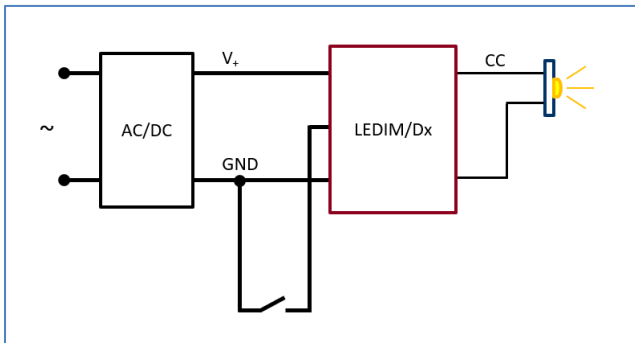

Figure 5: Pushbutton wiring illustrated

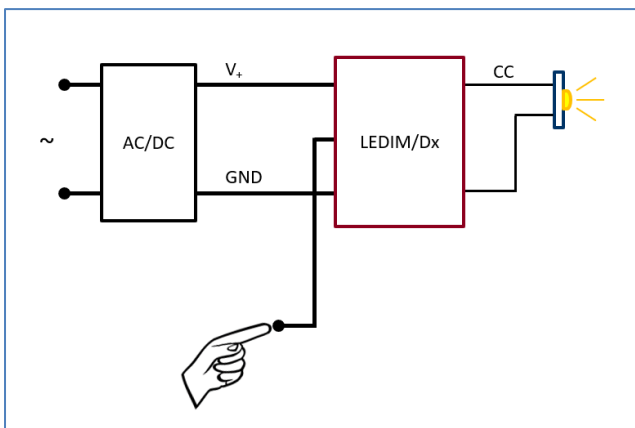

Figure 6: Touch wiring illustrated

7.2 Touch/Pushbutton Dimming Commands

The most obvious touch command is the “short touch”, which simply switches the light on and off (if the device is not in locked state). To understand the full command set, see the table below:

Touch Command	Impact	Remarks
short touch when off	Switching to “on”, last brightness is restored.	When first touch after power-on, the last stored brightness is set.
short touch when on	Switching to “off”, brightness setting is saved.	Brightness setting is non-volatile during power-down.
long touch when off	Switching to “on”, minimum brightness is set.	Brightness is increased when user remains touching.
long touch when on	Brightness is increased or decreased, depending on the last dimming before: always the opposite direction is taken. When the maximum or minimum is passed, the direction is reversed. After three such cycles dimming is stopped to prevent accidental infinite up/down-dimming.	Maximum and minimum are not “points” on the dimming curve, but “plateaus”. When passing the maximum brightness plateau, a short blink is given for acknowledgement. “Minimum” here means the <i>minimal brightness setting</i> , which is not off.
triple touch when not locked	The current state (brightness setting or even off) is frozen; the touch function is locked (except for the next triple touch to unlock).	An acknowledge blink is fired. Locking is volatile when power-down.
triple touch when locked	The touch function is unlocked. The current state/brightness remains.	An acknowledge blink is fired.
normal short or long touch when locked	When three times “normal touch” has occurred during one minute, a triple blink is fired to remember the user, that the device is currently locked.	A triple blink (3x) is fired, indicating an illegal operation.

NOTE: Features mentioned in grey will be added soon in upcoming firmware versions.

8. Integration

8.1 Touch Dimming Requirements

As touch dimming only can work, when user contact “makes a difference”, please consider:

- When integrating D2 into a (metal) lamp housing, which is also the touch surface, D2's CC outputs must be decoupled to reduce parasitic capacity.
- When the LED engine's PCB is made of Aluminum, it might be a critical condition to have the engine's heat sink electrically connected to the touch surface (e.g. the lamp housing). The parasitic capacity of the LED engine can cause malfunctions in touch dimming here. Please use thermal conducting pads⁴ instead of thermal paste (blue pad in Figure 7) to avoid.
- COBs or LED engines made of ceramic material are less critical in terms of parasitic capacity. So are cases, where the LED engine is electrically separated from the touch surface (see Figure 8).
- For further questions please contact support@ledim.de.

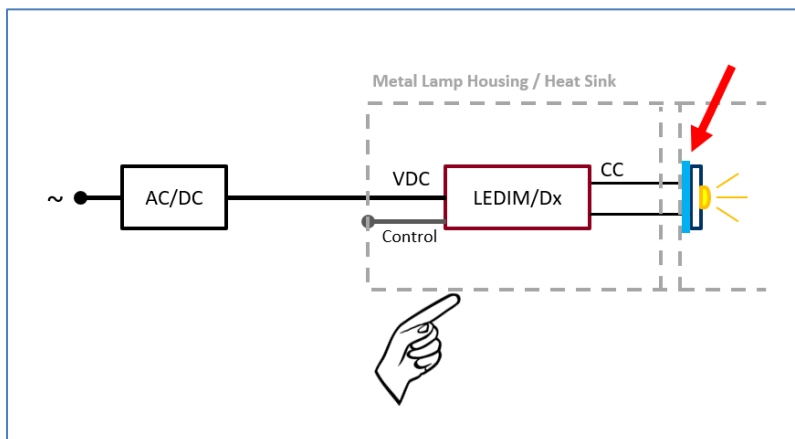

Figure 7: Critical Condition: Heat Sink connected to lamp housing with Alu PCB

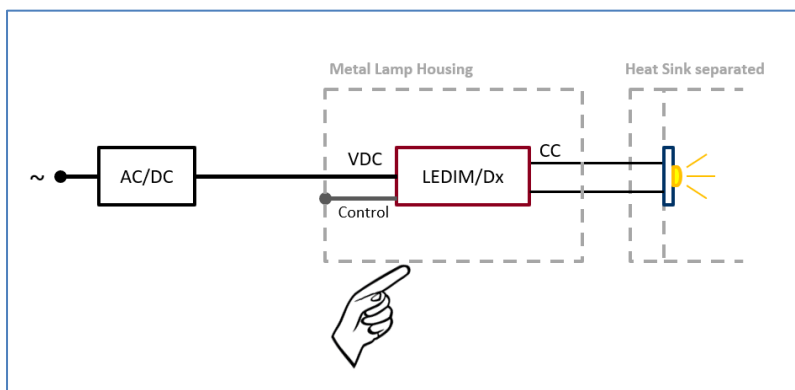

Figure 8: Less Critical Condition: Heat Sink not connected to lamp housing

⁴ Use thermal pads with thickness of at least 0.3 mm.

8.2 Other Requirements



CAUTION:

The device must not be stressed. The mounting area flatness must be chosen reasonable.



The device must be protected against electrostatic discharge during manufacturing, as well as during regular operation. Users must neither touch the device nor the components on it.



CAUTION:

The device must not be used outside the operating temperature range. Please refer to the derating diagram below for proper usage.

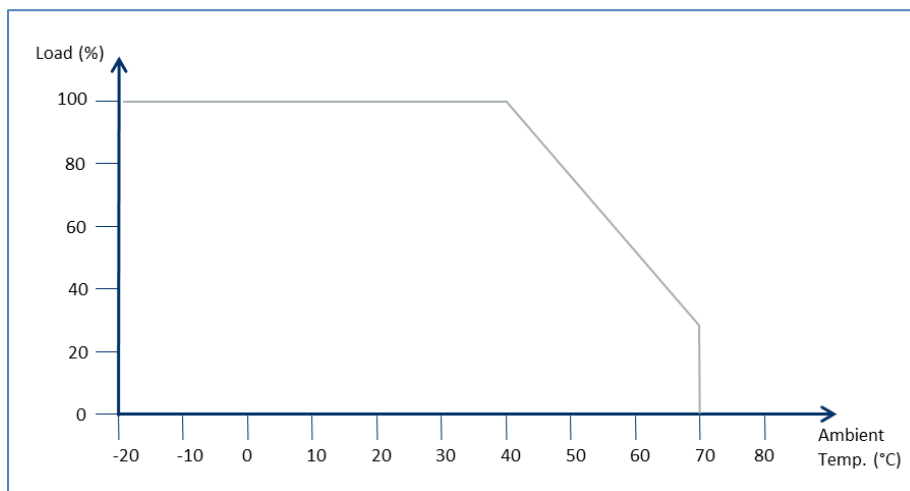

Figure 9: Derating Diagram

8.3 Typical Integration/Mounting the Device

D2 is typically integrated into a luminaire by mounting it to an even surface using screws and standoffs or spacers. Proper cooling must be ensured! The device can be mounted using M3 screws and standoffs or spacers. D2 can also be fixed by using a zip-tie preferably around its long side. Proper insulation must be ensured e.g. by putting D2 in heat shrink tubing. When D2 uses touch dimming, please refer to section 8.1. Damages caused by wrong mounting are not covered by warranty.



CAUTION:

- D2 must not be used outside the operating temperature range. Please refer to section 8.2 for proper usage.
- The device must not be stressed by the tensile force of the zip-tie. Please choose the tension carefully when applying the cable-tie.
- Proper insulation must be ensured. The top or the bottom side of the PCB must not be in contact with any conductive material.

8.4 Connector Pinout D2

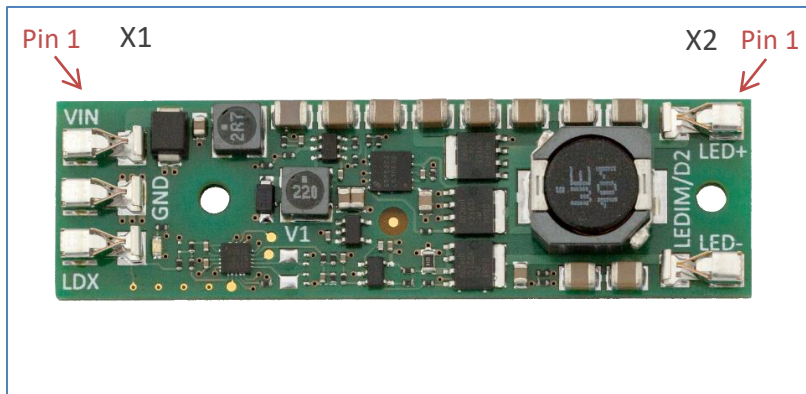

Figure 10: Connector Pinout V Variant

X1 – Supply voltage and dimming input:

Pin 1: Supply input (V_{in})
Pin 2: GND
Pin 3: Touch/Pushbutton/LDX

X2 – Load Output (CC):

Pin 1: LED output +
Pin 2: LED output –

8.5 Connection multiple Devices

Multiple LEDIM/D2 devices can be wired together simply by realizing a parallel arrangement. Please Note: Parallel arrangement only works with LDX connections (e.g. from bridges), **not** with touch nor potentiometer dimming.



CAUTION:

Please ensure, the power supply and cabling meet the electrical requirements (e.g. maximum current and voltage). Do not connect **more than 10 control signals together!**

Please see the LEDIM/Dx Application Notes for further details.

8.6 Output Wiring Scenarios

As the general wiring approach is quite simple – LED engines in a row – there are some aspects to consider. For an in-depth discovery of the various possibilities please refer to the LEDIM Dx Application Notes.



CAUTION:

Both LED+ and LED- lines must be free of any other potentials. Connect only to the appropriate LED signals. Do not connect to LED+ or LED- outputs of other drivers.

9. Maintenance/Service

The device has no serviceable parts inside. Thus, the device itself is to be the field replaceable unit (FRU). When replacing the unit, please ensure to apply the same measures as during the manufacturing process (e.g. the use of thermal paste, screw torque etc.).

10. Standard Compliance

LEDIM devices and accessories comply or will comply with all relevant standards and guarantee safe operation.

- Conformity: CE
- Environment: RoHS
- EMC: EN 55015, EN 61547

11. Safety Information and Precautions

- The device must only be utilized for its intended use.
- The LEDs are hot during operation and must never be touched.
- Eye safety/photobiological safety: Even though all used components comply with EN 62471, direct viewing into the light emitting areas must be avoided under all circumstances. Measures must be taken to prevent users from directly viewing into the light emitting areas.
- The device itself and all its components must not be mechanically stressed.
- During assembly, manufacturing and operation conducting paths on the circuit board must not be damaged or destroyed.
- To avoid mechanical damage to the connecting cables, the module should be attached securely to the intended counterpart. Heavy vibration should be avoided.
- To operate the device safely, it is absolutely necessary to operate it with an electronically stabilized power supply protecting against short circuits, overload and overheating.
- To ease the luminaire/installation approval, power supplies and additional electronic control gear should carry the CE mark and must be certified. The declarations of conformity must include the appropriate standards. Check for the mark of an independent authorized certification institute.
- Installation of LED modules (with power supplies) needs to be made with regard to all applicable electrical and safety standards. Only qualified personnel should be allowed to perform installations.
- Correct electrical polarity needs to be observed. Wrong polarity will destroy the module and might cause further damages.
- Pay attention to standard ESD precautions when installing the module.
- The module, as manufactured, has no conformal coating and therefore offers no inherent protection against corrosion.
- Damage by corrosion will not be honored as a materials defect claim. It is the user's responsibility to provide suitable protection against corrosive agents such as moisture and condensation and other harmful influences.
- If the IP rating of the fixture should be higher than IP20, the design of the housing should be according to the IP standards in the application.
- Pay attention not to exceed the maximum operation temperature at T_c point, especially when the device is used in enclosed environment. Appropriate measures must be taken.

Room for your notes and sketches:

Room for your notes and sketches:
